

24

Maße in mm / Dimensions in mm

Ketten-Nr. Chain No.	Teilung Pitch t mm	Lichte Weite Inside width b mm	Bolzen- ϕ Pin ϕ d ₁ mm	Buchsen- ϕ Bush ϕ d ₂ mm	Rollen- ϕ Roller ϕ d ₃ mm	Laschenabmessung Plate dimensions			Bruchlast (Einstrang) Breaking load (single- strand) N
						g ₁ mm	g ₂ mm	s mm	
FVT 63	63, 100, 125, 160	22	12	18	40	40	25	4	63 000
FVT 90	63, 100, 125, 160, 200, 250	25	14	20	48	45	27,5	5	90 000
FVT 112	100, 125, 160, 200, 250	30	16	22	55	50	30	6	112 000
FVT 140	100, 125, 160, 200, 250, 315	35	18	26	60	60	37,5	6	140 000
FVT 180	125, 160, 200, 250, 315, 400	45	20	30	70	70	45	8	180 000
FVT 250	125, 160, 200, 250, 315, 400	55	26	36	80	80	50	8	250 000
FVT 315	160, 200, 250, 315, 400	65	30	42	90	90	55	10	315 000
FVT 400	160, 200, 250, 315, 400	70	32	44	100	90	55	12	400 000
FVT 500	160, 200, 250, 315, 400, 500	80	36	50	110	100	60	12	500 000
FVT 630	200, 250, 315, 400, 500	90	42	56	120	120	70	12	630 000

Die angegebenen Teilungen sind genormt; es werden auch Zwischengrößen hergestellt! The indicated pitches are standardised; intermediate sizes are also available.

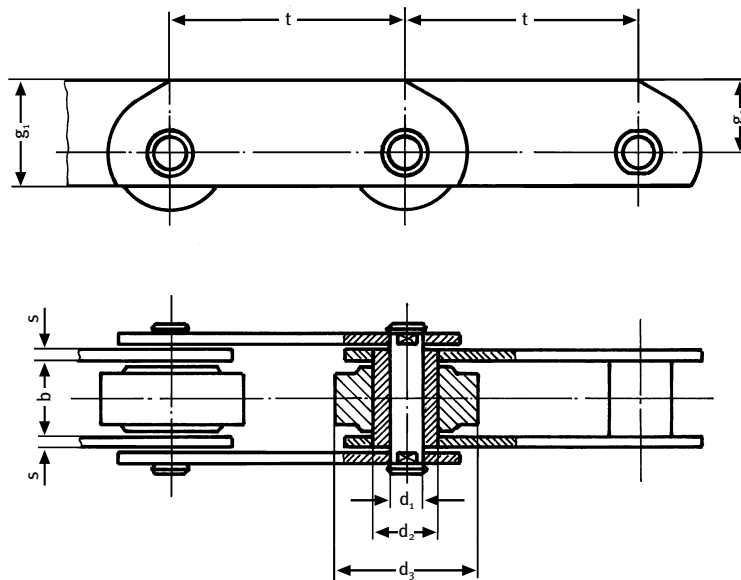

Maße in mm / Dimensions in mm

Ketten-Nr. Chain No.	Teilung Pitch t mm	Lichte Weite Inside width b mm	Bolzen- ϕ Pin ϕ d ₁ mm	Buchsen- ϕ Bush ϕ d ₂ mm	Rollen- ϕ Roller ϕ d ₃ mm	Laschenabmessung Plate dimensions			Bruchlast (Einstrang) Breaking load (single- strand) N
						g ₁ mm	g ₂ mm	s mm	
MT 56	63, 80, 100, 125, 160, 200, 250, 315	24	10	15	42	30	45	4	56 000
MT 80	80, 100, 125, 160, 200, 250, 315	28	12	18	50	32,5	50	5	80 000
MT 112	80, 100, 125, 160, 200, 250, 315	32	15	21	60	40	60	6	112 000
MT 160	100, 125, 160, 200, 250, 315	37	18	25	70	45	70	7	160 000
MT 224	125, 160, 200, 250, 315, 400	43	21	30	85	60	90	8	224 000
MT 315	160, 200, 250, 315, 400	48	25	36	100	65	100	10	315 000
MT 450	200, 250, 315, 400, 500	56	30	42	120	80	120	12	450 000
MT 630	250, 315, 400, 500	66	36	50	140	90	140	14	630 000
MT 900	250, 315, 400, 500	78	44	60	170	120	180	16	900 000

Die angegebenen Teilungen sind genormt; es werden auch Zwischengrößen hergestellt! The indicated pitches are standardised; intermediate sizes are also available.

